

FEATURES

- COMPLETE TRANSMITTER SIL MODULE.
- WIDE 10Kbps BANDWIDTH.
- WIDE VOLTAGE 'A' RANGE 6 - 12V DC.
- LOW VOLTAGE 'F' RANGE 2.5 - 4V DC.
- 5 VOLT 'F5' RANGE AVAILABLE.
- DTI APPROVED FOR USE IN THE U.K.
- DIRECTLY COMPATIBLE WITH R.F. SOLUTIONS FM RECEIVER UNITS.
- UP TO 200 METRES RANGE.
- AVAILABLE AS 418MHz (0.25mW ERP)
- AVAILABLE AS 433MHz (10mW ERP)
- ANALOGUE OR DIGITAL INPUTS.

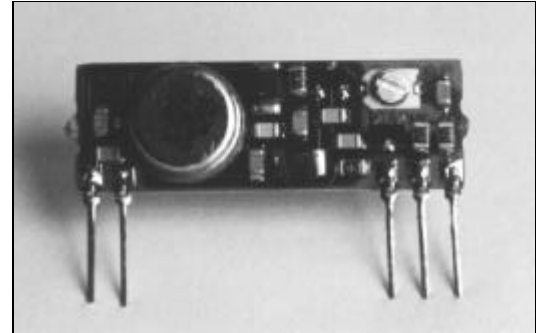

APPLICATIONS

- REMOTE SWITCHING
- REMOTE DATA COMMS
- GARAGE DOOR OPENERS
- ALARM SYSTEMS
- REMOTE TELEMETRY SYSTEMS.
- PAGERS

GENERAL DESCRIPTION

The R.F. Solutions range of FM Radiometrix Transmitters are complete single in line board modules capable of transmitting analogue or digital data up to 200 metres.

The units are suitable for general purpose telemetry applications where small size and high data rates are needed. These transmitters are designed to be used in conjunction with R.F. Solutions' series of Receivers (see data sheet FMRX1-XXX). Each unit is supplied complete and ready to operate.

Several versions of the transmitter are available in either 418 or 433MHz frequency, with either 0.25mW or 10mW ERP (RF power output)

The transmitter may also be supplied as a bare board or as a custom solution unique to customer-specific requirements. Please contact R.F. Solutions for further information.

BLOCK DIAGRAM

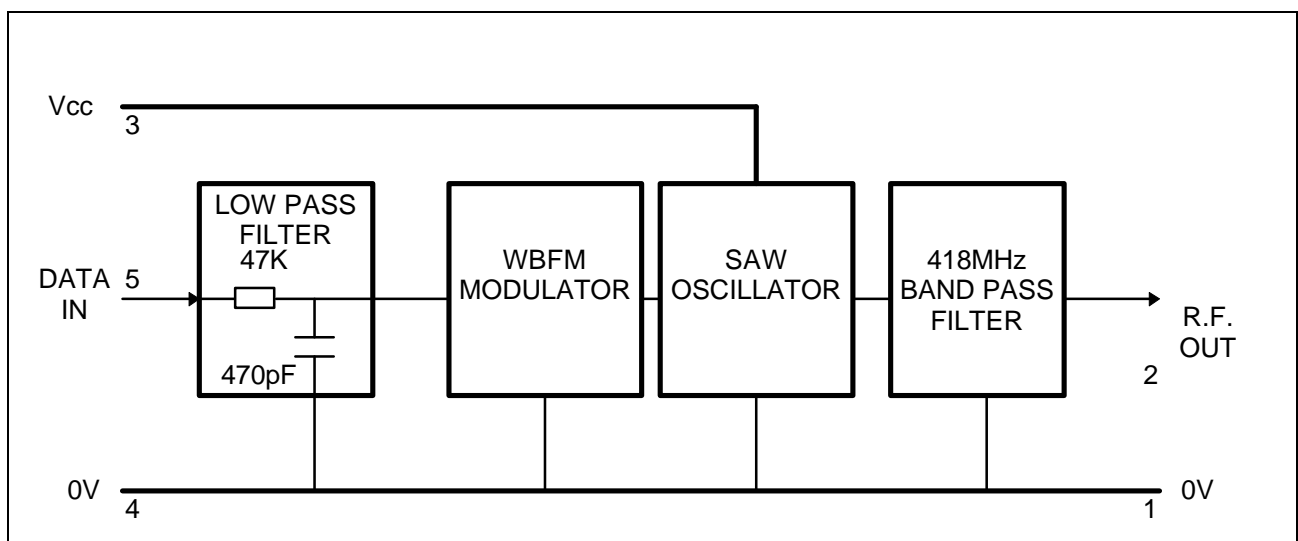

OPERATIONAL DESCRIPTION

Data in can accept data in either digital or direct analogue form (AFSK). The input frequency bandwidth ranges from DC to 10KHz; however, it is not possible to pass data with a DC component because of frequency errors and drifts between the transmitter and receiver. The frequency differences between transmitter and receiver will produce a DC offset error which will result in the receiver module producing errors on long high or low pulses which exceed the maximum pulse width specification (please refer to the Receiver data sheet, RF Solutions Doc FMRX1-XXX).

Data in should be driven from a CMOS logic output. The power supply for the CMOS circuit should be the same as that for the transmitter.

Analogue drive (e.g. two tone FSK) is possible; however the peak to peak level must be in the range 5 to 9V, and never fall below 0V. Please note that there may be some 2nd harmonic distortion due to the varactor modulator (typically <15%). This can be reduced somewhat by predistorting the analogue waveform.

LICENCE EXEMPTION

This range of Radio transmitters is approved by the Department of Trade & Industry (D.T.I. Specification MPT1340) in the U.K., and therefore the user requires no radio operating licence in the U.K. Please note however the following requirements to comply with MPT1340;

1. All transmitters shall use integral antennas only. Receivers may use an external or integral antenna. An integral antenna is defined as one which is designed to be connected permanently to the transmitter or receiver without the use of an external feeder.
2. The equipment in which the module is used must carry an inspection mark located on the outside of the equipment which is clearly visible. It shall state "MPT1340 W.T. Exempt". The minimum dimensions of the mark shall be 10 x 15mm and the figure height shall be not less than 2mm.

ANTENNA DESIGN

The range achieved from the system is dependant on the choice and position of the antenna. The space around the antenna is as important as the antenna itself. The optimum position is to locate the antenna so that it protrudes directly out the top of the transmitter box. If this is not possible due to other design constraints, try to keep the antenna away from other metal in the system such as transformers, batteries and PCB tracks, especially ground planes. In particular, the 'HOT' end of the antenna should be kept as far away as possible from these.

For further information on Antenna design please see our full product catalogue which gives recommended applications guidance.

PIN ASSIGNMENTS

PIN No	NAME	DESCRIPTION
1	R.F. GND	Ground Plane. The Antenna radiates against this (Internally connected to pin 4)
2	R.F. OUT	Connect to Antenna (Output Impedance = 50Ω)
3	Vcc	Supply Voltage
4	Vss	0 Volt Supply (Internally connected to pin 1)
5	DATA IN	Input pin. Should be driven by CMOS Drive with same supply as pin 3

TECHNICAL SPECIFICATION FOR FM-TX1-418A

ABSOLUTE MAXIMUM RATINGS

Supply Voltage (Vcc to GND).....'A' = -0.7 to +13 Volts. 'F' = -0.7 to +6 Volts
 Voltage on Modulation Input (Pin 5).....-0.7 to +13 Volts.
 Storage Temperature.....-40 to +100° Celsius.
 Operating Temperature.....-10 to +55° Celsius.

Ambient temperature = 20° Celcius. Supply Voltage Vcc = 8.0 Volts.

ELECTRICAL CHARACTERISTICS	MIN	TYPICAL	MAX	DIMENSION	SEE NOTE
Supply Voltage	6		12	V	
Supply Current (Vcc = 6.0V)	3.0	6.0	10.0	mA	
Supply Current (Vcc = 9.0V)	5.0	10.0	15.0	mA	
Supply Current (Vcc = 12.0V)	8.0	14.0	20.0	mA	
Radiated Power (ERP) (Vcc = 6.0V)	-16	-10	-7	dBm	1
Radiated Power (ERP) (Vcc = 9.0V)	-13	-8	-5	dBm	1
Radiated Power (ERP) (Vcc = 12.0V)	-10	-6	-3	dBm	1
Transmission Frequency		418		MHz	
Initial Frequency Accuracy	-50	0	+50	KHz	
Overall Frequency Accuracy	0	+80	0	KHz	2
FM Deviation (+/-)	15	25	40	KHz	3
Modulation Bandwidth analogue (-3dB)	DC		10	KHz	3
Modulation Digital Pulse Width	100			µS	4
Spurious Radiation	Meets MPT 1340				5

TECHNICAL SPECIFICATION FOR FM-TX1-418F

Ambient temperature = 20° Celcius. Supply Voltage Vcc = 3.0 Volts.

ELECTRICAL CHARACTERISTICS	MIN	TYPICAL	MAX	DIMENSION	SEE NOTE
Supply Voltage	2.7	3.0	4.0	V	
Supply Current (Vcc = 2.7V)			13.0	mA	
Supply Current (Vcc = 4.0V)			17.0	mA	
Conducted Power into 50Ω					
(Vcc = 2.7V)		-5		dBm	
(Vcc = 4.0V)		0		dBm	
Transmission Frequency		418		MHz	
Initial Frequency Accuracy	-40	0	+40	KHz	
Overall Frequency Accuracy	- 60	0	+60	KHz	2
FM Deviation (+/-)	15	25	40	KHz	
Modulation Bandwidth analogue (-3dB)	DC		20	KHz	
Modulation Digital Pulse Width	50			µS	5
Spurious Radiation	Meets MPT 1340				4

NOTES

1. Module on 50 mm square ground plane, helical antenna
2. Supply Voltage 6 to 12 Volts for 'A' device and 2.7-4.0 for 'F' device, Temperature -10 to +55° Celcius.
3. High or Low Pulse
4. <-54 dBm in bands 41-68, 87.5-118, 162-230 & 470-862MHz.
<-36 dBm elsewhere below 1GHz, <-30dBm above 1GHz.
5. Standard Modulation: 2 KHz square wave, 0 - Vcc

TEST CIRCUIT

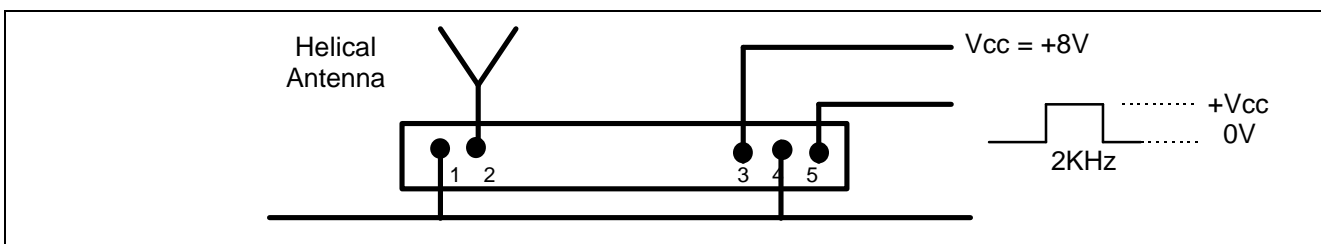

TECHNICAL SPECIFICATION FOR FM-TX1-433HP

ABSOLUTE MAXIMUM RATINGS

Supply Voltage (Vcc to GND).....'A' = -0.7 to +13 Volts. 'F' = -0.7 to +6 Volts
 Voltage on Modulation Input (Pin 5).....-0.7 to +13 Volts.
 Storage Temperature.....-40 to +100° Celsius.
 Operating Temperature.....-10 to +55° Celsius.

Ambient temperature = 20° Celcius. Supply Voltage Vcc = 8.0 Volts.

ELECTRICAL CHARACTERISTICS	MIN	TYPICAL	MAX	DIMENSION	SEE NOTE
Supply Voltage	6		12	V	
Supply Current (Vcc = 6.0V)	3.0	6.0	10.0	mA	
Supply Current (Vcc = 9.0V)	5.0	10.0	15.0	mA	
Supply Current (Vcc = 12.0V)	8.0	14.0	20.0	mA	
Radiated Power (ERP) (Vcc = 6.0V)	-16	-10	-7	dBm	1
Radiated Power (ERP) (Vcc = 9.0V)	-13	-8	-5	dBm	1
Radiated Power (ERP) (Vcc = 12.0V)	-10	-6	-3	dBm	1
Transmission Frequency		433.920		MHz	
Initial Frequency Accuracy	-80	0	+80	KHz	
Overall Frequency Accuracy	- 100	0	+100	KHz	2
FM Deviation (+/-)	15	25	40	KHz	3
Modulation Bandwidth analogue (-3dB)	DC		10	KHz	3
Modulation Digital Pulse Width	100			µS	4
Spurious Radiation	Meets ETSI 300 - 220				4

TECHNICAL SPECIFICATION FOR FM-TX1-433F

Ambient temperature = 20° Celcius. Supply Voltage Vcc = 3.0 Volts.

ELECTRICAL CHARACTERISTICS	MIN	TYPICAL	MAX	DIMENSION	SEE NOTE
Supply Voltage	2.5	3.0	4.0	V	
Supply Current					
(Vcc = 2.5V)			12.0	mA	
(Vcc = 4.0V)			15.0	mA	
Conducted Power into 50Ω					
(Vcc = 2.5V)		-5		dBm	
(Vcc = 4.0V)		0		dBm	
Transmission Frequency		433.920		MHz	
Initial Frequency Accuracy	-80	0	+80	KHz	
Overall Frequency Accuracy	- 100	0	+100	KHz	2
FM Deviation (+/-)	15	25	40	KHz	5
Modulation Bandwidth analogue (-3dB)	DC		10	KHz	5
Modulation Digital Pulse Width	50			µS	
Spurious Radiation	Meets ETSI 300 - 220				4

NOTES

- Module on 50 mm square ground plane, helical antenna (fig 5A)
- Supply Voltage 6 to 12 Volts for 'A' device and 2.5-4.0 for 'F' device, Temperature -10 to +55° Celcius.
- High or Low Pulse
- <-54 dBm in bands 41-68, 87.5-118, 162-230 & 470-862MHz.
<-36 dBm elsewhere below 1GHz, <-30dBm above 1GHz.
- Standard Modulation: 2 KHz square wave, 0 - Vcc

TEST CIRCUIT

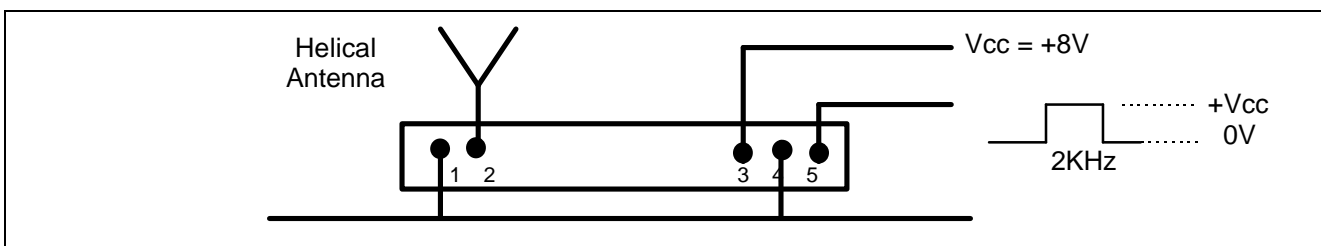

PERFORMANCE CHARACTERISTICS (FMTX1-418A)

Ambient Temperature = 20 °C.
Supply Voltage = +8.0 Volts.
(unless otherwise stated)

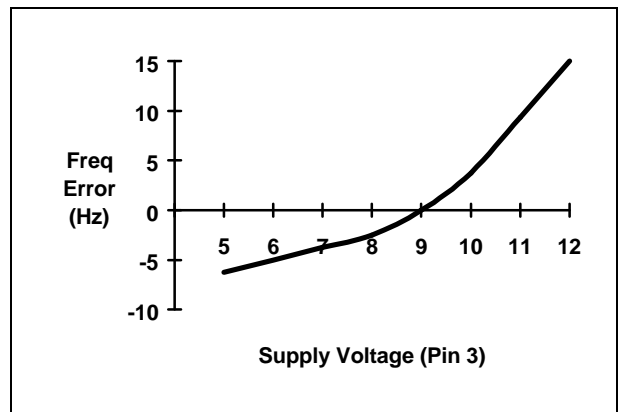
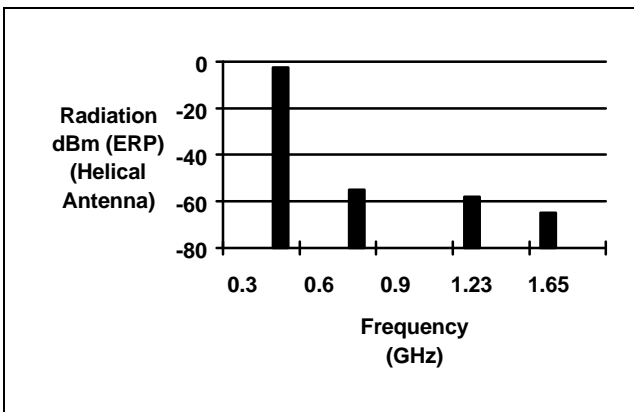
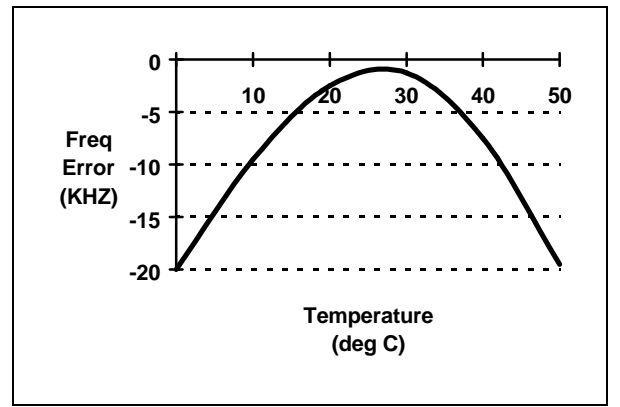
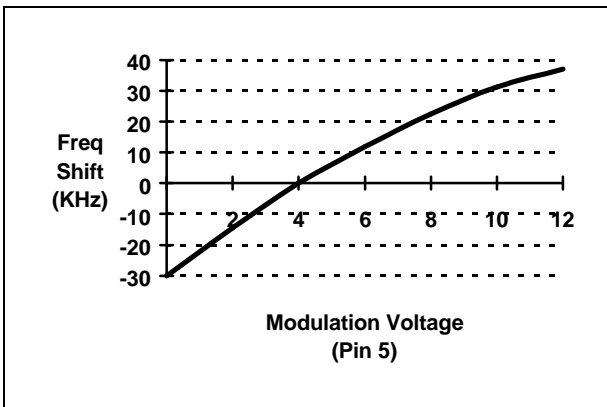
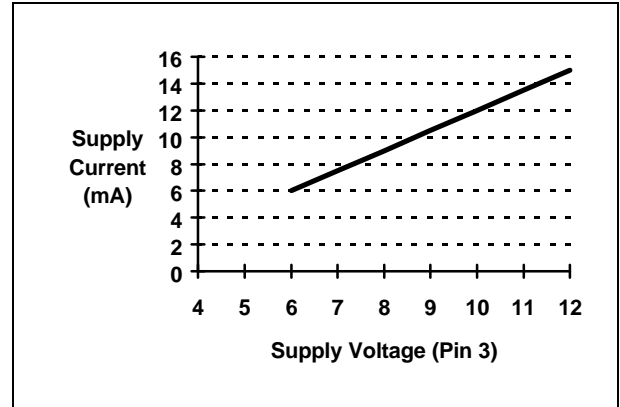
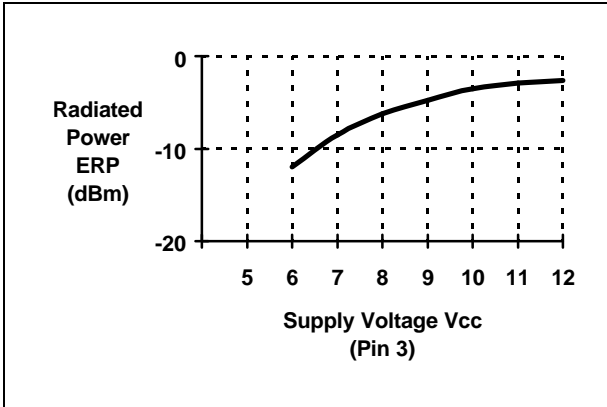

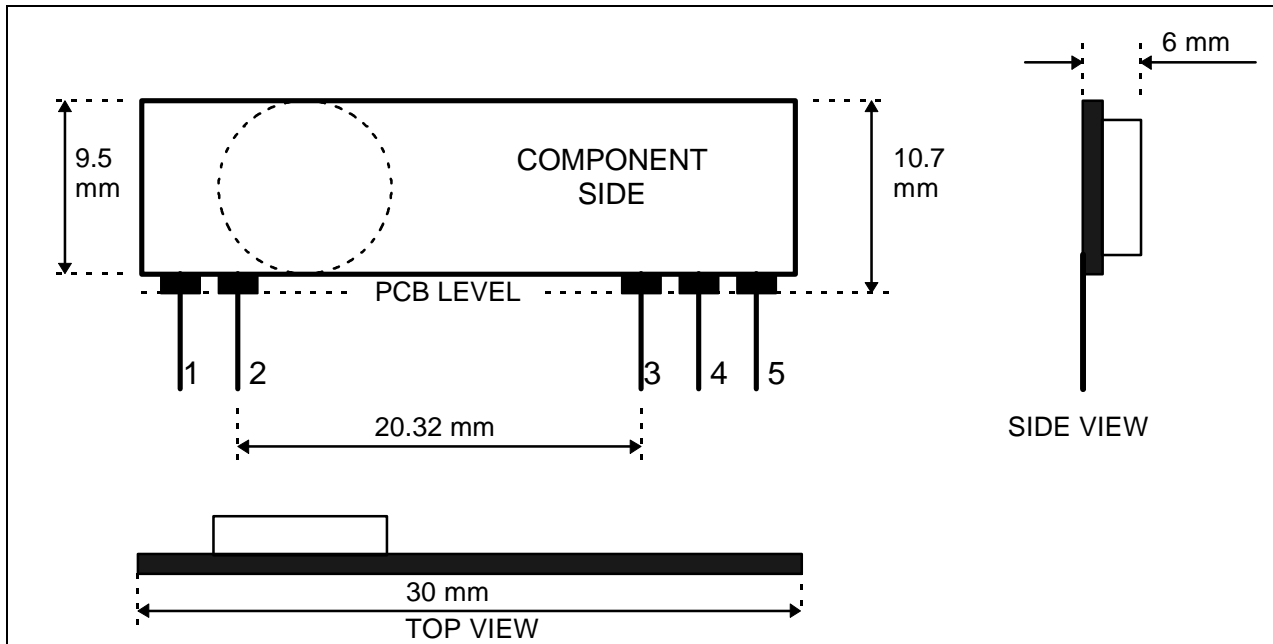
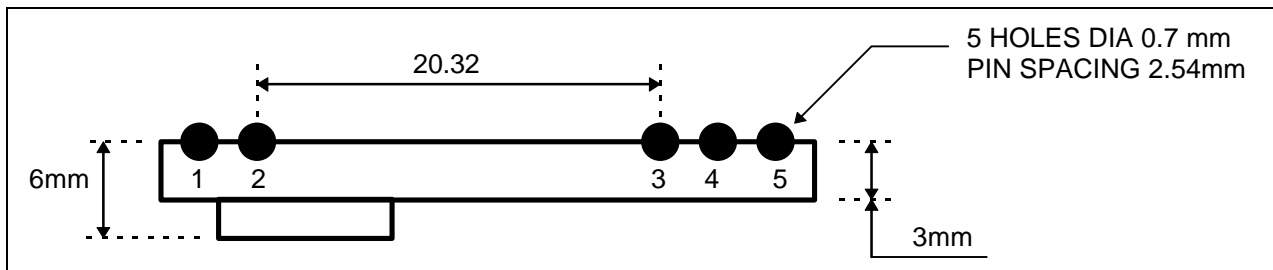
MECHANICAL DETAILS

PCB MOUNTING DETAIL (TOP VIEW)

PART NUMBERING

PART No	DESCRIPTION	OPERATIONAL VOLTAGE
FM-TX1-418A	Transmitter. 418MHz	6 - 12Vdc
FM-TX1-418F	Transmitter. 418MHz	2.7 - 4Vdc
FM-TX1-418F5	Transmitter. 418MHz	5Vdc
FM-TX1-433HP	Transmitter. 433MHz (10mW ERP)	6 - 12Vdc
FM-TX1-433F	Transmitter. 433MHz	2.7 - 4Vdc
FM-TX1-433F5	Transmitter. 433MHz	5Vdc

Should you require further assistance, please call;

R. F. Solutions Ltd,
Pannets Building,
Railway Lane,
Lewes,
E Sussex, BN7 2AQ. England.
Tel +44 (0)1273 488 880. Fax +44 (0)1273 480 661.
Email icepic@pavilion.co.uk
<http://www.rfsolutions.co.uk>

RF Solutions is a member of the Low Power Radio Association.

RF module data appears courtesy of Radiometrix Ltd, Southall, Middlesex, England.



Information contained in this document is believed to be accurate, however no representation or warranty is given and no liability is assumed by R.F. Solutions Ltd. with respect to the accuracy of such information. Use of R.F.Solutions as critical components in life support systems is not authorised except with express written approval from R.F.Solutions Ltd.